



Leak Detection Catalog

Edition 2013

General

Applications	03
--------------------	----

Products

Modular System Leak Detectors

for universal integration into industrial and automated leak testing systems

T-Guard	04
LDS3000	06
Modul1000	08
Calibrated leaks for System Applications	10

Helium Leak Detectors (vacuum)

Pernicka 700H	12
UL1000	14
UL1000 Fab	16
UL5000	18
Accessories for Vacuum Leak Detectors	20
Connection Components	22
Calibrated leaks for Vacuum Applications	23

Sniffer Leak Detectors

Helium Sniffer Leak Detectors

Protec P3000 (XL)	24
-------------------------	----

Refrigerant Sniffer Leak Detectors

Ecotec E3000	26
Ecotec E3000A	28
HLD5000	30

Hydrogen Sniffer Leak Detectors

Sensistor ISH2000	32
Sensistor ILS500 Leak Detection System	34
Sensistor XRS9012	36
EXTRIMA Ex certified	38
Calibrated test leaks for Sniffer Applications	40

Inquiry / order form for calibrated leaks	41
---	----

Applications

	Measurement Technology*													
	CHLD	ULTRATEST					WISE		QMS		IR	MOS		
Leak Detectors / Test Instruments	Pernicka 700H	UL1000	UL1000 Fab	UL5000	LDS3000	Modul1000	T-Guard	Protec P3000	Ecotec E3000	Ecotec E3000A	HLD5000	Sensistor ISH / ILS	Sensistor XRS	EXTRIMA
Applications														
Semiconductor production	◆	◆	◆						◆ ¹⁾					
Automotive industry	◆	◆			◆	◆	◆	◆	◆		◆	◆		
Aircraft construction industry										◆		◆		◆
Refrigeration		◆			◆	◆		◆	◆		◆	◆	◆	
Air conditioning		◆			◆	◆	◆	◆	◆		◆	◆	◆	
Systems engineering		◆			◆	◆	◆					◆		

*Description:

CHLD: Cumulative Helium Leak Detection

ULTRATEST™: Sensor technology by INFICON

WISE™: Sensor technology by INFICON

QMS: Quadrupole Mass Spectroscopy

IR: Infrared technology

MOS: Metal Oxide Sensor

Helium Sensor T-Guard for easy Integration into Industrial Leak Testing Systems

INFICON T-Guard™ Leak Detection Sensor delivers the sensitivity and speed helium leak detectors are known for, at a cost similar to pressure decay systems.

It works with simple chambers at atmospheric pressure, so there is no need for costly and complex high vacuum chambers and pumps. That makes automated systems based on T-Guard an attractive alternative to pressure decay and water bath leak detection, providing up to 100 times the sensitivity with low cost of ownership and high ease of use. The measurements are also highly repeatable, even with large, warm or humid test objects.



USER ADVANTAGES

- Helium leak detection at the price of pressure decay
- Up to 100 times more sensitive than pressure decay and water bath systems (10^{-1} to 10^{-6} mbar l/s)
- Works at atmospheric pressure — no need for costly vacuum-tight chamber or high vacuum pump
- Maintenance-free INFICON Wise Technology™, proven in more than 1,000 systems
- Simple design maximizes reliability, reduces cost of ownership
- Small and light for easy system integration
- Measures big volumes and objects that are warm, humid or cannot stand vacuum
- Measurements not affected by temperature and humidity
- Designed for automated systems
- Flexible control by PLC, PC or optional display unit
- Storage of parameter settings for easy data transfer on an optional, attachable I-Stick

TYPICAL APPLICATIONS

- Wherever pressure decay and water bath systems are used or are not sensitive enough
- Leak detection for water coolers and radiators
- Big valves, e.g. for chemical applications
- Manufacturers of automotive gas lines and tanks, small heater coils, etc. that are now demanding greater leak tightness
- Leak detection involving warm, humid or large parts, where the pressure decay method is ineffective
- Other markets where helium vacuum leak detection has been considered too costly or too complex

SPECIFICATIONS	T-GUARD
Minimum detectable leak rate	1 x 10 ⁻⁶ mbar l/s
Measurement range	5 decades
Test chamber pressure	1 atm
Time constant of the leak rate signal	< 1 s
Helium sensor	Wise Technology™
Run up time	< 3 min
Hose connectors	6 mm
Control inputs	6 x PLC compatible (max. 35 V)
Status / Trigger outputs	8 x relay contacts (max. 60 V DC / 25 V AC / 1 A)
Chart recorder output lin/log	2 x 0-10 V, programmable
Recommended fore pump	two-stage diaphragm
Power supply demand	24 V DC
Typical power consumption	< 100 W
Type of protection	IP40
Dimensions (L x W x H)	258 x 130 x 272 mm; 10.2" x 5.1" x 10.7"
Weight	4.5 kg / 10 lbs
Noise level dB (A)	< 56
ORDERING INFORMATION	PART NUMBER
T-Guard™ Leak Detection Sensor	540-001
T-Guard™ Leak Detection Sensor, Profibus version	540-002
Options, Accessories	
Display unit for table-top use	551-100
Display unit for rack installation	551-101
Connecting cable for display unit, 1 m	551-103
Connecting cable for display unit, 5 m	551-102
Set of connecting plugs	551-110
T-Guard™ connection hoses	
0.5 m length	540-011
1.0 m length	540-012
2.0 m length	540-013
Chamber connector	200 002 615
Set of filters	200 001 680
I/O testbox	200 002 490
Two-stage diaphragm fore pump, 24 V	200 002 929
I-Stick	200 001 997

Modular Leak Detector LDS3000 for System Integration into Industrial Leak Testing Systems

With the LDS3000, INFICON is opening a new chapter in the success story of leak detection systems. The successor to the LDS2010 is setting new standards for accuracy, reproducibility of measurement results and speed of leak detection. The LDS3000 is extremely compact. The small dimensions 13 x 9.45 x 11.1 in. (330 x 240 x 280 mm) make it even easier to integrate it into leak detection systems. More importantly, the space requirements and installation expense have been reduced even further by dispensing with a 19" control module and improving the cabling considerably. In addition, there is an optional touch screen for easy operation and an optional field bus connection.

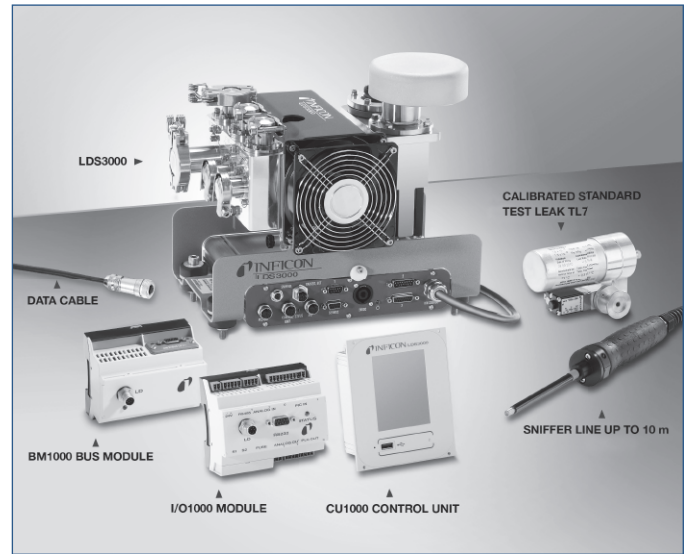

System schematics LDS3000

USER ADVANTAGES

- Compact design allows individualized, custom integration into leak detection systems
- Communicative diversity through a wide range of analog and digital interfaces like RS232, RS485, USB, Profibus
- Considerably improved cabling
- Fast, optimized response times with I-CAL
I-CAL is the effective algorithm for quick, reliable detection of the smallest leaks in the sensitive measurement range. Cycle times are decreased as a result and greater sensitivity is achieved. I-CAL has been successfully used with INFICON products for several years
- Calibration via internal calibrated leak; also external or dynamic calibration is possible while pumping down is in progress. New, patented routine allows calibration of the LDS3000 within 20 seconds
- The great helium pumping speed and compression of the high-performance turbomolecular pump make leak detection applications resistant to downtimes caused by helium contamination. The pump allows intake pressures up to 18 mbar for applications with minimal detection limit requirements
- LDS2010 compatibility mode

TYPICAL APPLICATIONS

The flexibility of the LDS3000 makes the instrument ideal for the integration into complex helium leak detection systems.

- Airbag parts
- Evaporators, condensers, compressors
- Valves
- Brake lines, fuel lines
- Hydraulic components
- Engines

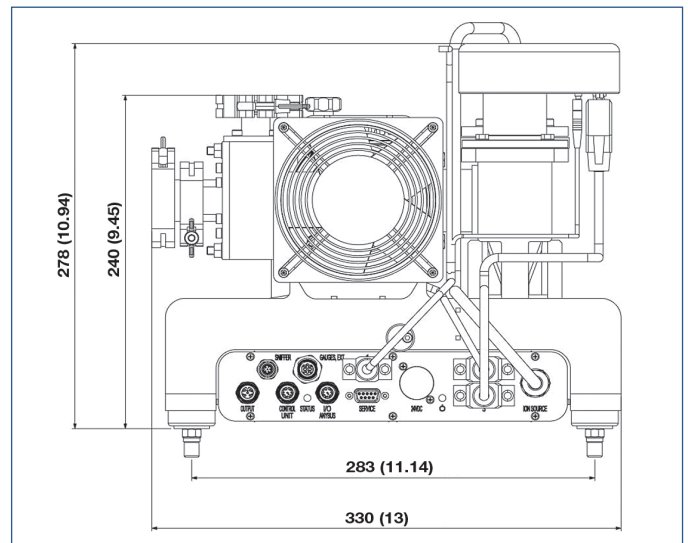

Dimensional drawing of the mass spectrometer module in mm (inch).

SPECIFICATIONS	LDS3000
Minimum detectable leak rate: ULTRA mode FINE mode GROSS mode SNIFFER mode	$\leq 1 \cdot 10^{-11}$ mbar l/s (> 5 l/s Helium pumping speed) $\leq 5 \cdot 10^{-11}$ mbar l/s (1.7 l/s Helium pumping speed) $\leq 1 \cdot 10^{-9}$ mbar l/s $\leq 1 \cdot 10^{-7}$ mbar l/s
Units of measurement (selectable)	mbar l/s, Pa m ³ /s, atm cc/s, g/a, ppm
Maximum permissible inlet pressure GROSS mode FINE mode ULTRA mode	18 mbar 0.9 mbar 0.2 mbar
Response time	< 1 s
Ion source	2 longlife Iridium filaments, Yttrium-oxide coated
Vacuum connections	DN 16 KF / DN 25 KF
Digital inputs/outputs	10 inputs, 8 outputs (when used with I/O1000)
Control input	SPS-compatible (max. 35 V)
Chart recorder output lin/log	0 - 10 V
Interface	RS232, RS485 or field bus systems
Dimensions (L x W x H)	330 x 240 x 280 mm (13 x 9.45 x 11.1 in.)

ORDERING INFORMATION	
PART NUMBER	PART NUMBER
Basic components:	Options:
LDS3000 basic unit 560-300	CU1000 Control unit 560-320
I/O 1000 module (input/output) 560-310	DIN rail power supply 24V, 10A 560-324
BM1000 bus module (Profibus) 560-315	Internal test leak TL7 560-323
additional bus modules upon request	Pump module
Data cable (MSB-I/O1000)	(complete, incl. connection accessories)
5 m cable length 560-335	TRIVAC D 4 B, 1-phase motor 230 V, 50/60 Hz 145 11
10 m cable length 560-340	Sniffer valve 145 20
Note: A I/O1000 module or BM1000 module as well as a data cable are necessary for the operation of a LDS3000. The data cables can be used for connecting to an I/O1000 module or a BM1000 module and the CU1000 operating unit.	Sniffer line, incl. handpiece, with 200 mm sniffer tip
	3 m cable length 145 21
	5 m cable length 145 22
	10 m cable length 145 23
	Replacement sniffer tip, 400 mm cable length 200 04 642

Helium Leak Detector Modul1000

Building up a leak test bench was never easier. The Modul1000 is the world first leak detector that fulfills jobs which are normally done by a PLC. The detector itself provides all necessary valves for a vacuum leak test and controls the complete leak test process from charging the test object with helium until venting of the test chamber.

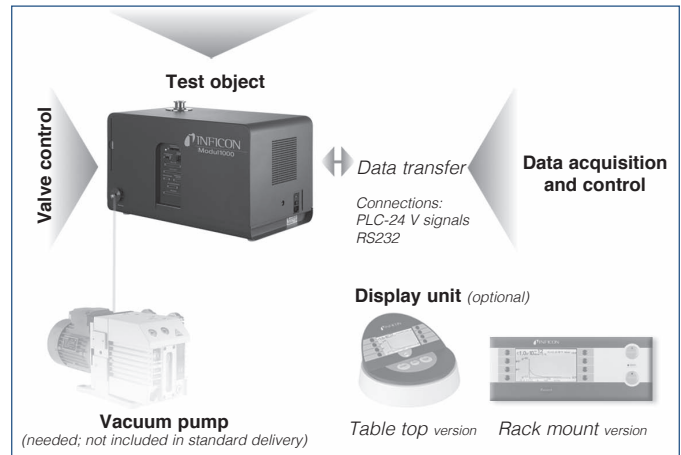

Modul1000 system schematics

USER ADVANTAGES

- Implemented "Commander" software menu for direct control of test benches and the complete leak test process.
- Easy to operate
- The choice between two different types of optional display units which can be placed away from the main unit for a maximum flexibility in test bench design.
- Low impact for rising helium background and contamination as a consequence of the high compression ratio of the turbo molecular pump
- The high compression turbo molecular pump allows the use of cost-effective single stage roughing pumps.
- Rugged mass spectrometer system with dual filament ion source (3 years warranty) ensures high uptime and low maintenance cost
- Switching over from vacuum leak detection to sniffer leak detection allows for immediate pin-pointing of the leak during the same test step
- Optional remote control for wired (up to 28 m) or wireless (up to 100 m) operation with 3.5" full colour touch screen display (see page 22)

TYPICAL APPLICATIONS

The Modul1000 was especially designed for the integration into medium automated test benches.

- Evaporators, condensers, compressors
- Valves
- Brake lines, fuel lines
- Hydraulic components
- Engines

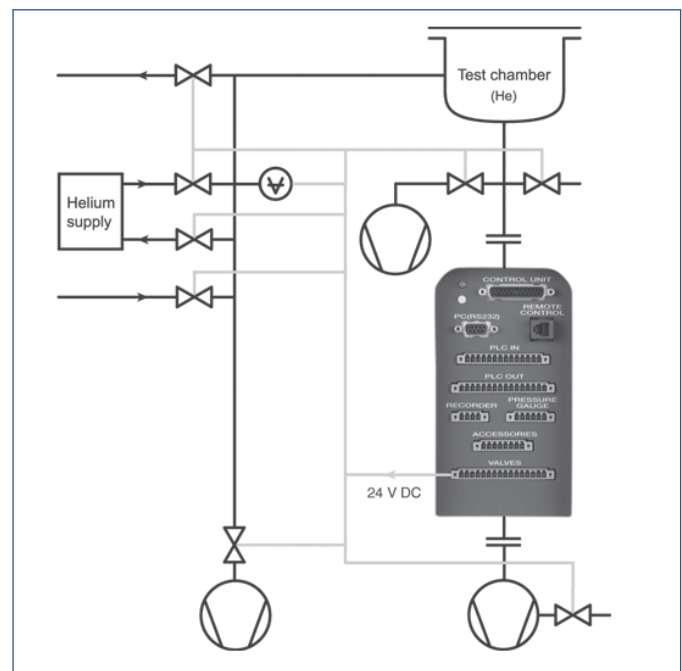

Example: Test station with Helium supply. Implemented "Commander" software menu for direct control of test systems

SPECIFICATIONS	MODUL1000
Minimum detectable leak rate VACUUM mode SNIFFER mode	< 5 x 10 ⁻¹² mbar l/s < 5 x 10 ⁻⁸ mbar l/s
Maximum inlet pressure	0.4 mbar 3 mbar (Modul1000b)
Operational mode	wide range without crossover (12 decades)
Helium pumping speed at inlet	2.5 l/s 0.1 l/s (Modul1000b)
Ion source	2 longlife Iridium filaments, Yttrium-oxide coated
Start-up time	< 3 minutes
Inlet port / Fore-vacuum port	DN 25 KF
Power supply	100 - 240 V, 50/60 Hz
Control inputs	8 x PLC compatible (max. 35 V)
Status / Valve control / Trigger outputs	9 / 11 / 3 x relay contacts (max. 60 V AC / 25 V DC / 1 A)
Chart recorder output lin/log	2 x 0-10 V, programmable
Recommended fore-vacuum pump	2.5 - 16 m ³ /h, wet or dry
Dimensions (width x depth x height)	535 x 350 x 339 mm (21.1 x 13.8 x 13.4 in)
Weight	30 kg (66 lbs)
ORDERING INFORMATION	PART NUMBER
Modul1000, vacuum version	550-300A
Modul1000, vacuum and sniffer version	550-310A
Modul1000b, vacuum and sniffer version	550-330A
Display unit for table-top use	551-100
Display unit for rack installation	551-101
Connecting cable for display unit, 0.7 m 5 m	551-103 551-102
Set of connecting plugs	551-110
Sniffer line SL200	140 05
Remote control	
RC1000C remote control, wired including 4 m coiled cable	551-010
RC1000WL remote control, wireless including wireless transmitter	551-015
Wireless transmitter for connection > 2 leak detectors	551-020
Extension cable, 8 m for RC1000C	140 22
Test chamber TC1000	551-005

Calibrated Leaks for System Applications

Manufacturers of helium leak testing systems require calibrated leaks of various sizes with individually adjusted leak rates for the purpose of setting up and calibrating their systems.

Depending on the type of application, these calibrated leaks are either installed in the test sample as a master leak or are installed in the test chamber itself.

INFICON offers calibrated leaks which are capable of meeting the requirements concerning type and required leak rate.

USER ADVANTAGES

- Various types adapted to different customer requirements
- Simple to operate
- Easy to install
- Ideal installation dimensions
- All calibrated leaks are supplied with a factory certificate indicating their leak rate

TYPICAL APPLICATIONS

- As a master calibrated leak built directly into the test sample
- Directly installed to the test chamber
- Use as a calibrated leak for sniffer applications

CALIBRATED INTEGRAL LEAK WITH HELIUM RESERVOIR

The integral Helium test leak is for use in a vacuum test chamber and is designed for easy filling and refilling by the customer. It is used for

- Calibration of the vacuum system
- Evaluation of the machine factor for the system
- Verification of the test procedure



CONTURA Z integral test leak



Calibrated leaks with screw-in sleeve (left), pin-type casing (center), cylindrical casing (right)

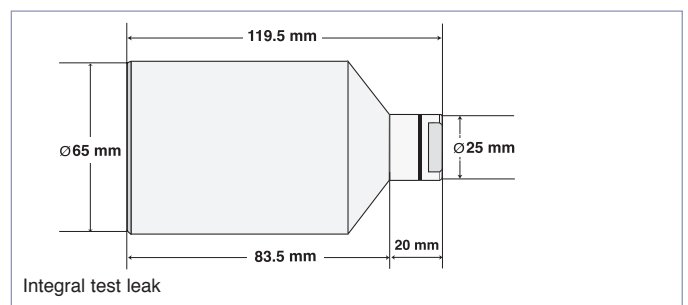
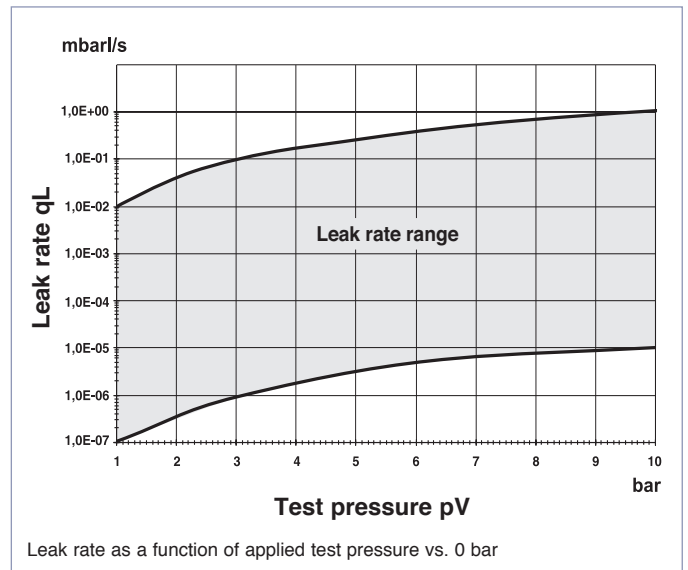

CALIBRATED LEAK WITH PIN TYPE CASING

Helium calibrated leaks without gas reservoir (capillary type of leak) for sensitivity and signal response time determinations during vacuum leak detection.

A purging valve with hose nozzle permits a rapid exchange of the gas in the dead volume.

CALIBRATED LEAK WITH CYLINDRICAL CASING

The test gas connection is either by a VCO fitting or a 10 mm hose nozzle for flexible connections.

All calibrated test leaks for systems are designed for a max. working temperature of 80 °C.

CALIBRATED LEAK WITH SCREW-IN SLEEVE

Used as a master leak to check the entire helium leak testing system.

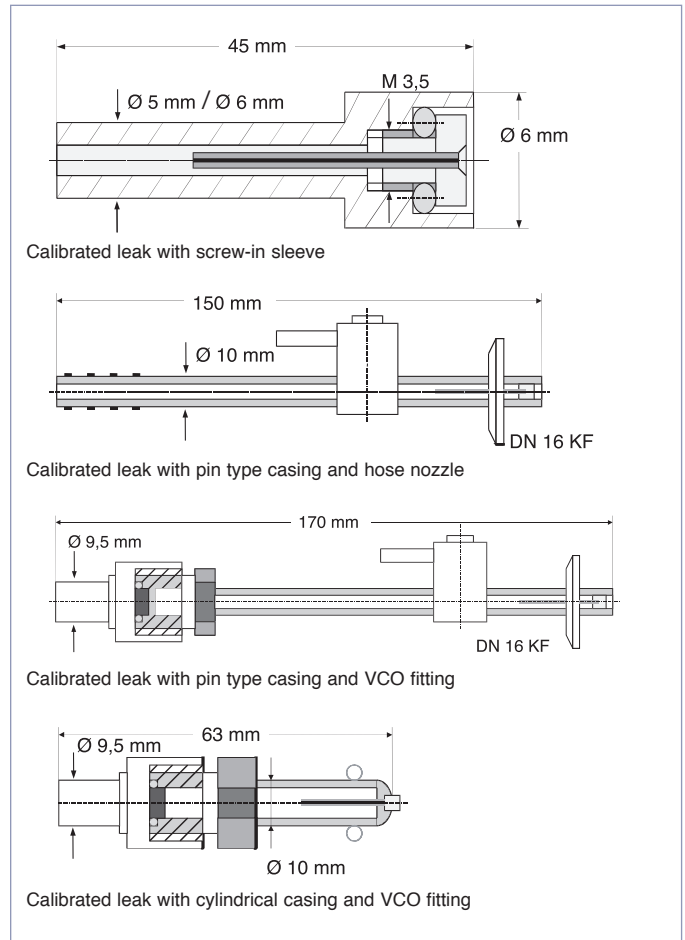

ORDERING INFORMATION

CALIBRATED LEAK	LEAK RATE RANGE	MAX. OPERATING PRESSURE	PART NUMBER
CONTURA Z integral test leak	10 ⁻⁴ mbar l/s	1 bar against vacuum	143 15S
Screw-in sleeve, 5 mm Ø	on request	20 bar - up to 40 bar *	143 00
Screw-in sleeve, 6 mm Ø	on request	20 bar - up to 40 bar *	143 16
Pin-type casing and hose nozzle	on request	6 bar	143 08
Pin-type casing and hose nozzle, TL 4	10 ⁻⁴ mbar l/s	6 bar	155 65
Pin-type casing and hose nozzle, TL 6	10 ⁻⁶ mbar l/s	6 bar	155 66
Pin-type casing and VCO fitting	on request	6 bar	143 04
Cylindrical casing and VCO fitting	on request	6 bar	143 12

* up to 40 bar if the capillary is glued-in by the customer

Note: For enquiry and order please complete the form on page 41 and forward it to your INFICON dealer.

Cumulative Helium Leak Detector Pernicka 700H

The Cumulative Helium Leak Detector (CHLD) combines mass spectrometer expertise with cryogenic ultra-high vacuum. The Pernicka 700H offers hermetic testing superior to conventional GROSS and FINE leak methods.

This technique can be applied to any hermetically sealed device which either contains a gas such as Nitrogen, Helium, Argon, Krypton, Xenon, etc. or can be bombed by Helium.

USER ADVANTAGES

- High sensitivity for smallest detectable leak rates $> 4 \times 10^{-14}$ mbar l/s
- Combining FINE and GROSS leak tests into single operation results in fast and effective testing procedures
- Simultaneous detection of Fluorocarbons, Nitrogen, Argon, Xenon, etc.
- Intelligent vacuum design with rugged cryogenic and turbo-molecular pumps
- High vacuum at high helium pumping speed
- Rugged Quadrupole mass spectrometer ensures long system uptime and low maintenance costs
- Integrated LCD monitor provides simplified operation
- Onboard computer provides real-time data reading and recording
- Environmentally friendly – no toxic or hazardous material required to run tests
- Suitable for leak test methods according to
 - MILStd-750, method 1071, procedure CH1-CH2
 - MILStd-883, method 1014, procedure CH1-CH2

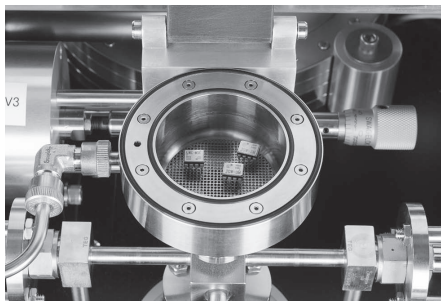

CHLD 700H
probe chamber with test components



TYPICAL APPLICATIONS

- High-reliability electronics, such as space/satellite parts
- Gas-filled components
- Large Hybrid packages
- Ultra-small volume devices, such as SMD packages
- Implantable medical devices, such as pacemakers, cochlear implants

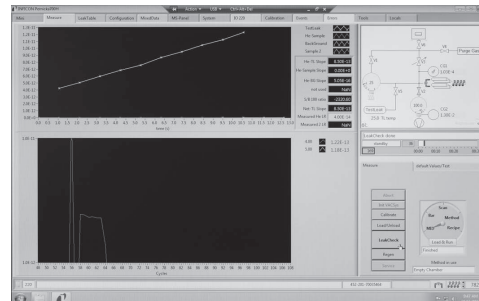

CHLD 700H
comfortable LCD display for simplified operation

SPECIFICATIONS	PERNICKA 700H
Minimum detectable leak rate for Helium (FINE mode)	> 4 x 10 ⁻¹⁴ mbar l/s
Maximum detectable leak rate for Helium (GROSS mode)	> 10 ⁻⁴ mbar l/s
Detectable masses	2 - 200
Mass Spectrometer	Quadrupole type
Calibrated built-in test leak in the range	10 ⁻¹⁰ mbar l/s
Test port	DN 16 CF
Vacuum pump system	turbomolecular pump oil sealed roughing pump cryo pump
Supply voltages unit	110/120 V, 50/60 Hz 15 A 220/240 V, 50/60 Hz 10 A
Cryo compressor (air cooled)	208-240 V, 50/60 Hz 10 A
Gas supply	
Valve operation	Compressed air, 100 - 110 PSI
Purge gas	Argon, 0.5 - 1 PSI
Ambient conditions	Intended for indoor use only
Max. permissible height above sea level (during operation)	2000 m
Operational temperature	15 - 28 °C (60 - 80° F)
Max. relative humidity	80%
Overvoltage category	II
Degree of contamination	2 (EN 61010)
Weight	245 kg (540.13)
Dimensions (W x H x T)	660 x 1390 x 870 mm (26 x 54.5 x 34.25 in)

ORDERING INFORMATION		
PART NUMBER	PART NUMBER	
Pernicka 700H	Options:	
Cumulative helium leak detector system,	Double O-ring test chamber	
110 V version	Large	551-710
230 V version	Medium	551-711
	Small	551-712
	Small metal seal test chamber	551-715
	High purity gas regulator, customized for Nitrogen/Argon, pressure range 30 or 240 PSI US or DIN connection to gas bottle	551-700S

Helium Leak Detector UL1000

The mobile UL1000 with a rotary vane pump is an automated leak detector offering fast pumpdown and short response time for quick testing results in industrial systems.



USER ADVANTAGES

- Wide measurement range over 15 decades
- Short pumpdown and response time
- Mobile all metal housing for added convenience with uncompromised maneuverability
- **I-CAL** (Intelligent **C**alculation **A**lgorithm for **L**eak rates) to ensure fastest response time to leaks in all measurement ranges
- Zero function with automatic integration time alignment for fast and reliable test results
- Intelligent vacuum design with rugged roughing pump and multiple inlet turbomolecular pump that provides high helium pumping speed with high compression
- Rotatable display and user interface allows simple and easy control and interaction with the unit
- Self protection features to protect the UL1000 from helium and particle contamination
- Auto purge cycle to ensure clean up and readiness for test
- Software updates via email easily possible
- Rugged mass spectrometer system with 2 filament ion source (3 years warranty) ensures long running time and low maintenance cost
- Built-in test leak for internal calibration to ensure accurate test results
- Built-in software menu "Auto Leak Test" function to perform tests of hermetically sealed components. By use of the optional test chamber TC1000 (see page 21) this test runs automatically
- Optional remote control for wired (up to 28 m) or wireless (up to 100 m) operation with 3.5" full colour touch screen display (see page 22)

TYPICAL APPLICATIONS

Leak testing and quality control of all types of components including

- Automotive components
- Refrigeration and air conditioning components and sub-assemblies
- Hermetically sealed electronic devices
- Heat exchangers

Advanced software menu Auto Leak Test

This function controls the test cycle and allows entering of test parameters like

- measuring cycle time
- trigger level
- number of parts tested

The status of the test cycle can always be monitored on the display. The optional test chamber TC1000 (see page 36) turns the UL1000 in a user-friendly workstation for the test of hermetically sealed parts.

The test starts automatically when closing the chamber lid, short cycle times can be achieved (10^{-9} mbar l/s in < 5 sec). The status of the test can always be monitored on the display. After the adjusted cycle time the test stops and the chamber will be vented. A selectable "Standby" mode keeps the chamber under vacuum while discontinuing the leak test. Protective functions prevent helium contamination by big leaker and ensure continuous operation.

SPECIFICATIONS	UL1000
Min. detectable leak rate for helium (Vacuum mode) *)	$< 5 \times 10^{-12}$ mbar l/s
Min. detectable leak rate for helium (Sniffer mode) *)	$< 5 \times 10^{-8}$ mbar l/s
Max. detectable leak rate for helium that can be displayed	0.1 mbar l/s
Max. inlet pressure	GROSS mode: 15 mbar FINE mode: 2 mbar ULTRA mode: 0.4 mbar
Pumping speed during evacuation	16 m ³ /h (11.2 cfm) at 50 Hz
Helium pumping speed	GROSS mode: max. 8 l/s FINE mode: 7 l/s ULTRA mode: 2.5 l/s
Time constant of the leak rate signal (blanked off, 63% final value)	< 1 s
Pumpdown time until ready to detect leaks (Background 5×10^{-9})	
Without additional volume	5 s
At a test volume of 1 litre	10 s
At a test volume of 10 litre	80 s
Response time (for a leak rate of 10^{-9} mbar l/s)	
Up to a volume of 1 litre	< 1 s
Up to volume of 10 litre	< 2 s
Time until ready for operation	< 3 min
Detectable masses	2,3,4 amu, H ₂ , ³ He, He
Mass spectrometer	180° magnetic sector field
Ion source	2 filaments, Iridium/Yttria oxide coated
Calibrated leak TL7 (built-in) leak rate in the range	10^{-7} mbar l/s
Units of measurement (selectable)	mbar l/s, Pa m ³ /s, Torr l/s, atm cc/s, ppm, g/a (only in sniffer mode)
Test port	25 KF
Adjustable triggers	2
Interface	RS 232
In/outputs	PLC compatible for control and status information
Chart recorder output	2 x 10 V
Supply voltages	230 V ($\pm 10\%$) 50 Hz 115 V ($\pm 10\%$) 60 Hz 100 V ($\pm 10\%$) 50/60 Hz
Power consumption	1100 VA
Dimensions (L x W x H)	1068 x 525 x 850 mm (42 x 21 x 33 inch)
Weight	110 kg (242 lbs)
Type of protection	IP 20
Permissible ambient temperature (during operation)	$+10$ °C $+40$ °C
*) per AVS and EN 1518	
ORDERING INFORMATION	PART NUMBER
UL1000, 230 Volts, 50 Hz, EU mains plug	550-000A
UL1000, 115 Volts, 60 Hz, US mains plug	550-001A
UL1000, 110 Volts, 60 Hz, Japan mains plug	550-002A
Test Chamber TC1000 incl. ESD wrist band	551-005
Test leak adapter for TC1000, DN 25 KF flange	200 001 797
RC1000C remote control, wired, including 4 m coiled cable	551-010
RC1000WL remote control, wireless, incl. wireless transmitter	551-015
Wireless transmitter for connection > 2 leak detectors	551-020
Extension cable, 8 m for RC1000C	140 22
Accessories:	
Toolbox with lock, attachable	551-000
Helium bottle holder	551-001
ESD mat	551 002
Sniffer line SL200, 4 m length	140 05
LeakWare PC software package	140 90

Dry Helium Leak Detector UL1000 Fab

The mobile UL1000 Fab with its dry vacuum system is an automatic leak detector offering fast pumpdown and short response time to meet the demanding requirements in semiconductor applications.



USER ADVANTAGES

- Wide measurement range over 15 decades
- Short pumpdown and response time
- Mobile all metal housing for added convenience with uncompromised maneuverability
- **I-CAL (Intelligent Calculation Algorithm for Leak rates)** to ensure fastest response time to leaks in all measurement ranges
- Zero function with automatic integration time alignment for fast and reliable test results
- Intelligent vacuum design with rugged scroll pump and multiple inlet turbomolecular pump that provides high helium pumping speed with high compression
- Rotatable display and user interface allows simple and easy control and interaction with the unit
- Self protection features to protect the UL1000 Fab from helium and particle contamination
- Auto purge cycle to ensure clean up and readiness for test
- Software updates via email easily possible
- Rugged mass spectrometer system with 2 filament ion source (3 years warranty) ensures long running time and low maintenance cost
- Built-in test leak for internal calibration to ensure accurate test results
- Built-in software menu “Auto Leak Test” function to perform tests of hermetically sealed components.
By use of the optional test chamber TC1000 (see page 21) this test runs automatically
- Optional remote control for wired (up to 28 m) or wireless (up to 100 m) operation with 3.5” full colour touch screen display (see page 22)

TYPICAL APPLICATIONS

- Leak testing of
 - Components
 - Chambers
 - Subassemblies
- used on
 - Semiconductor tools
 - Flat display tools
- Leak testing of hermetically sealed electronically devices

Advanced software menu Auto Leak Test

This function controls the test cycle and allows entering of test parameters like

- measuring cycle time
- trigger level
- number of parts tested

The status of the test cycle can always be monitored on the display. The optional test chamber TC1000 (see page 36) turns the UL1000 in a user-friendly workstation for the test of hermetically sealed parts.

The test starts automatically when closing the chamber lid, short cycle times can be achieved (10^{-9} mbar l/s in < 5 sec). The status of the test can always be monitored on the display. After the adjusted cycle time the test stops and the chamber will be vented. A selectable “Standby” mode keeps the chamber under vacuum while discontinuing the leak test. Protective functions prevent helium contamination by big leaker and ensure continuous operation.

SPECIFICATIONS	UL1000 FAB
Min. detectable leak rate for helium (Vacuum mode) *)	< 5 x 10 ⁻¹² mbar l/s
Min. detectable leak rate for helium (Sniffer mode) *)	< 5 x 10 ⁻⁸ mbar l/s
Max. detectable leak rate for helium that can be displayed	0.1 mbar l/s
Max. inlet pressure	GROSS mode: 15 mbar FINE mode: 2 mbar ULTRA mode: 0.4 mbar
Pumping speed during evacuation	25 m ³ /h (17.6 cfm) at 50 Hz 30 m ³ /h (21.1 cfm) at 60 Hz
Helium pumping speed	GROSS mode: max. 8 l/s FINE mode: 7 l/s ULTRA mode: 2.5 l/s
Time constant of the leak rate signal (blanked off, 63% final value)	< 1 s
Pumpdown time until ready to detect leaks (Background 5 x 10 ⁻⁹)	
Without additional volume	5 s
At a test volume of 1 litre	10 s
At a test volume of 10 litre	80 s
Response time (for a leak rate of 10 ⁻⁹ mbar l/s)	
Up to a volume of 1 litre	< 1 s
Up to volume of 10 litre	< 2 s
Time until ready for operation	< 3 min
Detectable masses	2,3,4 amu, H ₂ , ³ He, He
Mass spectrometer	180° magnetic sector field
Ion source	2 filaments, Iridium/Yttria oxide coated
Calibrated leak TL7 (built-in) leak rate in the range	10 ⁻⁷ mbar l/s
Units of measurement (selectable)	mbar l/s, Pa m ³ /s, Torr l/s, atm cc/s ppm, g/a (only in sniffer mode)
Test port	25 KF
Adjustable triggers	2
Interface	RS 232
In/outputs	PLC compatible for control and status information
Chart recorder output	2 x 10 V
Supply voltages	230 V (±10%) 50 Hz 115 V (±10%) 60 Hz 100 V (±10 %) 50/60 Hz
Power consumption	1100 VA
Dimensions (L x W x H)	1068 x 525 x 850 mm (42 x 21 x 33 inch)
Weight	110 kg (242 lbs)
Type of protection	IP 20
Permissible ambient temperature (during operation)	+10 °C+40 °C
*) per AVS and EN 1518	
ORDERING INFORMATION	PART NUMBER
UL1000 Fab, 230 Volts, 50 Hz, EU mains plug	550-100A
UL1000 Fab, 100/115 Volts, 50/60 Hz, US mains plug	550-101A
Test Chamber TC1000 incl. ESD wrist band	551-005
Test leak adapter for TC1000, DN 25 KF flange	200 001 797
RC1000C remote control, wired, including 4 m coiled cable	551-010
RC1000WL remote control, wireless, incl. wireless transmitter	551-015
Wireless transmitter for connection > 2 leak detectors	551-020
Extension cable, 8 m for RC1000C	140 22
Accessories:	
Toolbox with lock, attachable	551-000
Helium bottle holder	551-001
ESD mat	551 002
Sniffer line SL200, 4 m length	140 05
LeakWare PC software package	140 90

Dry Helium Leak Detector UL5000

The mobile UL5000 is designed to meet the most critical and demanding semiconductor applications, providing fast pumpdown time and delivering fast response time.

It is an ideal tool for bigger testing volumes > 50 l volume.



USER ADVANTAGES

- Wide measurement range over 15 decades
- Short pumpdown and response time
- Mobile all metal housing for added convenience with uncompromised maneuverability
- Software algorithm **HYDRO-S (HYDROgen-Suppression)** to enable test conditions to be reached quickly
- **I-CAL (Intelligent Calculation Algorithm for Leak rates)** to ensure fastest response time to leaks in all measurement ranges
- Zero function with automatic integration time alignment for fast and reliable test results
- Intelligent vacuum design with rugged Scroll pump and multiple inlet turbomolecular pump that provides high helium pumping speed with high compression
- Rotatable display and user interface allows simple and easy control and interaction with the unit
- Self protection features to protect the UL5000 from helium and particle contamination
- Auto purge cycle to ensure clean up and readiness for test
- Software updates via email easy possible
- New workstation design with optimal height work surface that includes an ESD mat and a lockable tool box
- Rugged mass spectrometer system with 2 filament ion source (3 years warranty) ensures long running time and low maintenance cost
- Built-in test leak for internal calibration to ensure accurate test results
- Optional remote control for wired (up to 28 m) or wireless (up to 100 m) operation with 3.5" full colour touch screen display (see page 22)

TYPICAL APPLICATIONS

Leak testing of

- Components
- Bigger chambers (> 50 l volume)
- Subassemblies

used on

- Semiconductor tools
- Flat display tools

SPECIFICATIONS	UL5000
Min. detectable leak rate for helium (Vacuum mode) *)	< 5 x 10 ⁻¹² mbar l/s
Min. detectable leak rate for helium (Sniffer mode) *)	< 5 x 10 ⁻⁸ mbar l/s
Max. detectable leak rate for helium that can be displayed	30 mbar l/s
Max. inlet pressure	GROSS mode: 15 mbar FINE mode: 2 mbar ULTRA mode: 0.4 mbar
Pumping speed during evacuation	25 m ³ /h (17.6 cfm) at 50 Hz 30 m ³ /h (21.1 cfm) at 60 Hz
Helium pumping speed	GROSS: max. 8 l/s FINE: max. 20 l/s ULTRA: > 20 l/s
Time constant of the leak rate signal (blanked off, 63% final value)	< 1 s
Pumpdown time until ready to detect leaks in the range of 10 ⁻⁹ mbar l/s	
Without additional volume	< 10 s
At a test volume of 10 litre	< 48 s
At a test volume of 50 litre	< 150 s
Response time (for a leak rate of 10 ⁻⁹ mbar l/s)	
Up to a volume of 10 litre	< 1 s
Up to volume of 50 litre	< 2 s
Venting (with test volume of 100 litres)	approx. 25 s
Time until ready for operation	< 3 min
Detectable masses	2,3,4 amu, H ₂ , ³ He, He
Mass spectrometer	180° magnetic sector field
Ion source	2 filaments, Iridium/Yttria oxide coated
Calibrated leak TL7 (built-in) leak rate in the range	10 ⁻⁷ mbar l/s
Units of measurement (selectable)	mbar l/s, Pa m ³ /s, Torr l/s, atm cc/s ppm, g/a (only in sniffer mode)
Test port	40 KF
Adjustable triggers	2
Interface	RS 232
In/outputs	PLC compatible for control and status information
Chart recorder output	2 x 10 V
Supply voltages	230 V (±10%) 50 Hz 115 V (±10%) 60 Hz 100 V (±10%) 50/60 Hz
Power consumption	1200 VA
Dimensions (L x W x H)	1080 x 530 x 1083 mm (42.5 x 21 x 42.6 inch)
Weight	140 kg (308 lbs)
Type of protection	IP 20
Permissible ambient temperature (during operation)	+10 °C+40 °C
*) per AVS and EN 1518	
ORDERING INFORMATION	PART NUMBER
UL5000, 230 Volts, 50 Hz, EU mains plug	550-500A
UL5000, 100/115 Volts, 50/60 Hz, US mains plug	550-501A
all UL5000 including Tool box and ESD mat	
RC1000C remote control, wired, including 4 m coiled cable	551-010
RC1000WL remote control, wireless, incl. wireless transmitter	551-015
Wireless transmitter for connection > 2 leak detectors	551-020
Extension cable, 8 m for RC1000C	140 22
Accessories:	
Helium bottle holder	551-001
LeakWare PC software package	140 90
Sniffer Line SL200, 4 m	140 05
Reduction piece 40/25 KF to connect SL200 to UL5000 inlet port	211-283

Accessories for Vacuum Leak Detectors

HELIUM SNIFFER LINE SL200 FOR THE UL1000/5000 AND MODUL1000

Helium sniffers in connection with the UL1000, UL5000 and the Modul1000 leak detectors are used for leak testing test samples which are pressurized with Helium. Besides pinpointing the leaks, it is possible to determine the leak rate of the escaping helium.

- Sniffer line connects directly to the inlet port
- Very fast response time < 1 sec
- Extremely low detection limit < 1 x 10⁻⁷ mbar l/s
- Rigid 120 mm sniffer tip (included)
- Connecting flange DN 25 KF

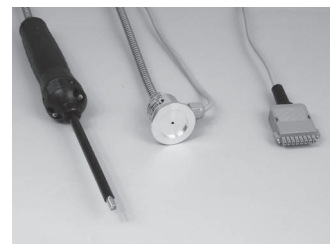

Helium sniffer line SL 200 P

HELIUM SNIFFERS QUICK-TEST QT100 FOR THE UL1000/5000, AND THE MODUL1000

- For greater distances up to 20 m between test object and leak detector
- Diaphragm pump for sucking the search gas
- Minimum detectable leak rate 1 x 10⁻⁶ mbar l/s
- Short response and decay times: 1 sec at 5 m, 8 sec at 20 m
- High sniffer velocity
- Built-in transformer for adaptation to any required power supply voltage 110-230 V AC



Helium sniffer QUICK-TEST QT 100 with sniffer

SPECIFICATIONS

	SAMPLE PROBES	
	SL200	QT100
Minimum detectable leak rate	< 10 ⁻⁷ mbar l/s	10 ⁻⁶ mbar l/s
Supply voltage	-	110 - 220 V, 50/60 Hz
Signal response time, approx.	at a length of 5 m 20 m	1 s 8 s
Connection flange	DN 25 KF	DN 25 KF
Weight	0.6 kg (1.32 lbs)	3.5 kg (7.72 lbs)

ORDERING INFORMATION

	PART NUMBER
Helium sniffer line, SL200 P, 4 m long, straight handle with red / green LED for go / no-go indication, rigid sniffer tip 120 mm	140 05
Helium sniffer QUICK-TEST QT100	155 94
Sniffer line for the QT100, 5 m	140 08
20 m	140 09

LEAKWARE

Windows PC software used for data acquisition, documentation of measurements, and to control the leak detector operation.

SEARCH GAS SPRAY GUN

The search gas spray gun with PVC hose (5 m long) is used for well aimed spraying of search gas at places where a leak is suspected.



Search gas spray gun

ORDERING INFORMATION

PART NUMBER

PC software LeakWare	140 90
Search gas spray gun	165 55
Rubber bladder (Helium reservoir for spray gun)	200 20 218
Hose clamp for rubber bladder	200 20 217

TEST CHAMBER TC1000 FOR THE UL1000/UL1000 FAB AND MODUL1000

- Turns the UL1000 / UL1000 FAB and the Modul1000 into a reliable and user-friendly workstation for testing of hermetically sealed parts (also according to MIL-STD 843, Method 1014)
- Easy to install
- Maintenance-free
- Volume (hemispherical shape): approx. 430 ccm
- Upper diameter / depth: 130 / 40 mm
- Material: Aluminum alloy, low outgasing rate
- Weight: 2.5 kg
- Vacuum connection: DN 25 KF
- Integrated sensor switch to start test in combination with UL1000 / UL1000 Fab and the Modul1000
- Clearly visible red/green LED's to display test results
- Calibration by an external test leak easy possible by using an optional adapter plate
- Protection of tested parts against static discharge by the standard ESD wrist band and an optional ESD mat (Cat. No. 551-002) for UL1000 / UL1000 Fab

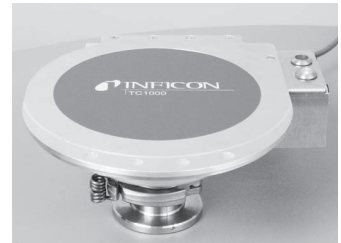

Test chamber TC1000



TC1000 in operation; exemplary menu function showed on the display

ORDERING INFORMATION

PART NUMBER

Test chamber TC1000 incl. ESD wrist band	551-005
Test leak adapter for TC1000, DN 25 KF flange	200 001 797

Remote Control for Vacuum Leak Detectors

REMOTE CONTROL RC1000 FOR THE UL1000/UL1000 FAB, UL5000 AND MODUL1000

- Up to 100 m wireless and up to 28 m wired operation of UL1000, UL1000Fab, UL5000, Modul1000 and UL200 leak detectors
- More than 8 hours battery lifetime
- Full color, 3.5" touch screen display
- Push buttons for basic operation features
- Leak rate displayed in digits, chart mode or bargraph mode
- Automatic or manual data recording
- Up to 24 hours storage of measured values
- Data copy via USB stick and download on PC
- Adjustable alarm trigger setting
- Robust design IP42
- Easy substitution of previous remote control version (Ref. No. 200 99 022)



ORDERING INFORMATION

PART NUMBER

RC1000C remote control, wired, including 4 m coiled cable	551-010
RC1000WL remote control, wireless, incl. wireless transmitter	551-015
Wireless transmitter for connection > 2 leak detectors	551-020
Extension cable, 8 m for RC1000C	140 22

Connection Components

When connecting accessories (helium sniffer probe and calibrated leaks) to a vacuum leak detector, the following reducers and components may be necessary:

ORDERING INFORMATION

	PART NUMBER
Reducers, stainless steel / FPM	
DN 25 / 16 KF	211-281
DN 40 / 25 KF	211-283
DN 40 / 16 KF	211-282
Centering rings	
DN 16 KF	211-059
DN 25 KF	211-068
DN 40 KF	211-070
Clamping rings	
DN 16 KF	211-001
DN 25 KF	211-002
DN 40 KF	211-003

The following metal hoses are recommended to connect the leak detectors to systems:

Nominal Width	Length	PART NUMBER
DN 16 KF	1.0 m	211-338
DN 16 KF	0.5 m	211-336
DN 25 KF	1.0 m	211-342
DN 25 KF	0.5 m	211-340
DN 40 KF	1.0 m	211-346
DN 40 KF	0.5 m	211-344

Calibrated Test Leaks with Gas Reservoir for Vacuum Applications

TL7

Capillary leak with helium reservoir and manual valve.
Leak rate range 10^{-7} mbar l/s. Connecting flange DN 10 KF.

TL8 / TL9

Helium test leak with helium reservoir and manual valve.
A special quartz bulb with a high helium permeation rate adjusts the constant gas flow. Connecting flange DN 10 KF.



USER ADVANTAGES

- Inured to pollution
- Metal-free flow reduction for low temperature dependence
- Inspection certificate (included) in accordance to DIN EN 10204:2004-3.1
- Highly accurate and reliable
- Determination of the nominal leak rate by comparison with a calibrated leak having a PTB certificate
- DKD certificate (optional) traceable to PTB

ORDERING INFORMATION

CALIBRATED LEAK WITH HELIUM RESERVOIR	LEAK RATE RANGE	PART NUMBER
TL 7 with hand valve	10^{-7} mbar l/s	142 10 / 115 14
TL 7 for UL200/UL1000/UL5000, Modul1000	10^{-7} mbar l/s	142 30
TL 8	10^{-8} mbar l/s	165 57
TL 8, DKD calibrated	10^{-8} mbar l/s	165 57DKD
TL 9	10^{-9} mbar l/s	144 08

Calibrated Test Leaks with Gas Reservoir for Vacuum and Sniffer Applications

TL4-6

Universal gas source for the fast insert in a variety of applications

Helium capillary leak for vacuum and sniffing applications.
Adjustable leak rate in the range between 10^{-4} to 10^{-6} mbar l/s. Besides helium, which is included in delivery, the TL4-6 is also usable with different kind of gases.



ORDERING INFORMATION

CALIBRATED LEAK	LEAK RATE RANGE	PART NUMBER
TL4-6, with helium gas reservoir	10^{-4} to 10^{-6} mbar l/s	155 80

Helium Sniffer Leak Detector Protec P3000(XL)

INFICON Protec P3000 and Protec P3000XL Helium Sniffer Leak Detectors are specifically designed for full-time sniffing applications in demanding production environments.

The Protec P3000(XL) brings increased levels of productivity and reliability to the sub-assembly and midproduction testing of refrigerators, freezers, air conditioners, automotive air conditioners, RAC components and similar products. Numerous features make it easy and comfortable to use, while making it more immune to careless or untrained operation. It is also fast to make the best use of your available cycle time. Protec P3000(XL) uses innovative INFICON Wise Technology in this robust, reliable and maintenance-free sensor. The Wise Technology sensor combined with the unique design and ruggedness of the leak detector, provides a very low cost of ownership and high up-time.



USER ADVANTAGES

- Improved system design compensates for operator error reducing the potential for missed leaks.
- Protec P3000(XL) provides the minimum detectable leak rate on the market.
- Protec P3000XL is unique for detecting leaks at a considerable distance.
- A small display in the ergonomically-designed probe handle shows the leak rate, so the operator can concentrate on the sniffing process and monitoring the leak rate at the same time.
- Built-in illumination source of the probe helps precisely position the sniffer tip.
- Multiple alarm functions make sure alarms cannot be overlooked.
- Built-in PRO-Check reference leak allows for easy and fast calibration at the production line at any time.
- I-Guide mode ensures your operator is testing the right locations with the correct technique.
- Leak rates can be displayed in refrigerant equivalents from a gas library.
- New, low-maintenance sensor yields high reliability and low cost of ownership.
- Automatic standby prevents intake of contaminants into the sniffer probe, thus saving filter and sensor life.
- Operating software is available in many languages.

TYPICAL APPLICATIONS

The Protec P3000(XL) is ideal for all helium sniffing applications of pressurized components that need to be leak tested.

- Refrigerating / air conditioning industries
 - Evaporators
 - Condensers
 - Valves
 - Compressors
 - Testing of pre-assembled air condition systems before filling with refrigerant
 - Testing of pre-assembled refrigerators and freezers before filling with refrigerant
 - Testing of pre-assembled heat pump systems before filling with refrigerant
- Automotive industry
 - Brake lines
 - Fuel lines
 - Hydraulic components
 - Engines
 - Testing of pre-assembled air conditioning systems before filling with refrigerant



Protec P3000RC
with external display unit for rack mounting

SPECIFICATIONS	PROTEC P3000	PROTEC P3000(XL)
Minimum detectable leak rate	1 x 10 ⁻⁷ mbarl/s	1x10 ⁻⁶ mbarl/s @ 3000 sccm 1x10 ⁻⁷ mbarl/s @ 300 sccm
Measuring scale	5 decades	4 decades @ 3000 sccm 5 decades @ 300 sccm
Sensor response time	450 ms	
Response time incl. sniffer line	< 0.7s	
Leak rate units	mbar l/s; Pa m ³ /s; ppm	
Refrigerant equivalent leak rates	g/a; oz/yr; lb/yr	
Start-up time	approx. 5 min	
Dimensions (width x depth x height)	610 x 265 x 370 mm (24 x 10.4 x 14.6 in)	
Weight	27 kg (60 lbs)	
Gas flow	300 sccm	300 / 3000 sccm
Ambient temperature range	10-45°C (50-113°F)	

ORDERING INFORMATION

	PART NUMBER		PART NUMBER
Protec P3000 (base unit), 230 V, 50 Hz	520-001	Sniffer tips for SL3000 (Protec P3000)	
100/115 V, 50/60 Hz	520-002	ST 312, 120 mm, rigid	12213
Protec P3000XL (base unit), 230 V, 50 Hz	520-003	FT 312, 120 mm, flexible	12214
100/115, 50/60 Hz	520-004	ST 200, 200 mm, rigid	12218
Remote controlled version without display unit		FT 250, 250 mm, flexible	12266
Protec P3000, RC, 230 V, 50 Hz	520-103	ST 385, 385 mm, rigid	12215
Protec P3000, RC, 110/115 V, 50/60 Hz	520-104	FT 385, 385 mm, flexible	12216
Protec P3000XL, RC, 230 V, 50 Hz	520-105	FT 600, 600 mm, flexible	12209
Protec P3000XL, RC, 110/115 V, 50/60 Hz	520-106	ST 400, 400 mm, 45° angled	12272
Display unit for Protec P3000RC		Sniffer tips for SL3000XL (Protec P3000XL)	
Table top version	551-100	ST312XL, 120 mm, rigid	521-018
Rack version	551-101	FT312XL, 120mm, flexible	521-019
Connecting cable for display unit		ST385XL, 385 mm, rigid	521-020
5 m length	551-102	FT385XL, 385 mm, flexible	521-021
0.7 m length	551-103	FT250XL, 250 mm, flexible	521-022
Sniffer line for Protec P3000 with integrated display and push-buttons		PRO-Check reference leak - Optional (Not included with delivery of Protec P3000)	521-001
SL3000-3, 3 m length	525-001	Spare reservoir for PRO-Check	521-010
SL3000-5, 5 m length	525-002	Calibrated leak with helium reservoir	
SL3000-10, 10 m length	525-003	S-TL 4, leak rate range 10 ⁻⁴ mbar l/s	122 37
SL3000-15, 15 m length	525-004	S-TL 5, leak rate range 10 ⁻⁵ mbar l/s	122 38
Sniffer line for Protec P3000XL with integrated display and push-buttons		S-TL 6, leak rate range 10 ⁻⁶ mbar l/s	122 39
SL3000XL-3, 3 m length	521-011	Holder for sniffer line SL3000(XL)	525-006
SL3000XL-5, 5 m length	521-012	Cover for reference leak port	525-007
SL3000XL-10, 10 m length	521-013	Water protection tip for SL3000	122 46
SL3000XL-15, 15 m length	521-014	Oil/water protection tip for SL3000XL	521-016
Sniffer line adapter for system integration for Protec P3000	525-005	Replacement filter for oil/water protection tip (100x)	521-017
for Protec P3000XL	521-015	Special filter cartridge for SL3000XL	521-023

Protec and Wise Technology are trademarks of INFICON.

Multi-Gas Sniffer Leak Detector Ecotec E3000

The Ecotec E3000 leak detector brings new levels of productivity and reliability to the final testing of refrigerators, freezers, automotive air conditioners and similar products. It is specifically designed for demanding production environments. Numerous features make it easy and comfortable to use while making it more immune to careless operation and minimizing operator errors. It is also fast to make the best use of your available cycle time. Innovative design and robustness keep the cost of ownership down and ensure very high up-time.

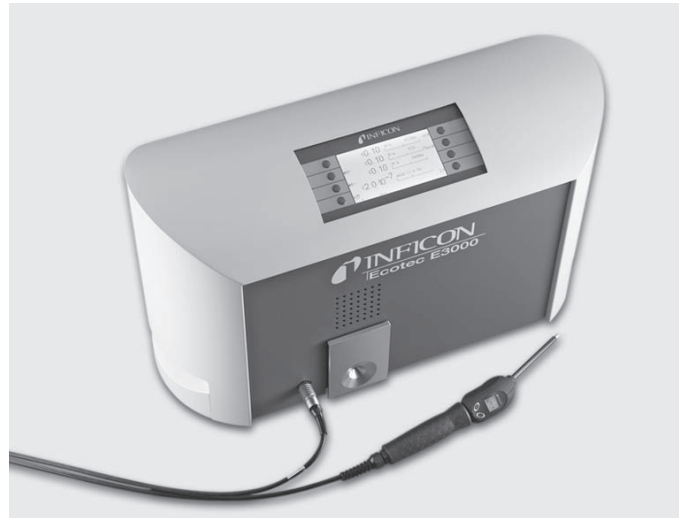

USER ADVANTAGES

- Improved system design compensates for poor sniffing operation reducing the potential for missed leaks
- IGS (Interfering Gas Suppression) ensures only leaks are detected
- Built-in illumination source on the probe helps precisely position the sniffer tip
- Unit can be operated via the probe display and probe buttons without access to the main unit
- Built-in ECO-Check reference leak allows for easy and fast calibration at the production line at any time
- Multiple alarm functions make sure alarms cannot be overlooked
- I-Guide (operator guiding mode) ensures your operator tests the right locations with the right technique
- Ergonomic probe design allows for easy and comfortable use
- Operating software is available in many languages

TYPICAL APPLICATIONS

- Refrigerators and freezers
- Transportation refrigeration
- Cooling and refrigeration systems
- Air conditioning units
- Water coolers
- Compressors and evaporators
- Halogen lamps
- Gas panels



Ecotec E3000RC
with external display unit for table top use

SPECIFICATIONS		ECOTEC E3000
Minimum detectable leak rate	R134a R600a Helium	0.05 g/a (0.002 oz/yr) 0.05 g/a (0.002 oz/yr) 1 x 10 ⁻⁶ mbar l/s
Measuring scale		0.05 – 999.99 g/a (0.015 – 99.999 oz/yr)
Sensor response time		0.3 s
Response time incl. sniffer line		0.8 s
Max no. of gases detected simultaneously		4
Leak rate units		g/a, oz/y, mbar l/s, ppm, Pa m ³ /s
Gas flow		160 sccm
Start-up time		< 2 min
Ambient temperature range		10 – 45 °C (50 – 113 °F)
Dimensions (W x H x D)		610 x 370 x 265 mm (24 x 14.6 x 10.4 in)
Weight		34 kg (75 lbs)

ORDERING INFORMATION

PART NUMBER		PART NUMBER	
Ecotec E3000 (base unit), 230 V, 50 Hz	530-001	ECO-Check reference leak R134a - optional (Not included with delivery of Ecotec E3000)	531-001
100/115 V, 50/60 Hz	530-002	Test leaks for refrigerants (2 - 5 g/a)	
Ecotec E3000RC without display unit		R134a	122 20
230 V, 50 Hz	530-103	R600a	122 21
100/115 V, 50/60 Hz	530-104	R404a	122 22
Display unit for Ecotec E3000RC		R502	122 23
Table top version	551-100	R22	122 25
Rack version	551-101	R152a	122 27
Connecting cable for display unit		R407c	122 28
5 m	551-102	R410a	122 29
0.7 m	551-103	R401a	122 30
Sniffer line with integrated display and push-buttons		R290	122 31
SL3000-3, 3 m length	525-001	R744 (CO ₂)	122 32
SL3000-5, 5 m length	525-002	Forming gas (10% hydrogen, 90% helium)	122 33
SL3000-10, 10 m length	525-003	R13B1 (Halon 1301)	122 34
SL3000-15, 15 m length	525-004	HFO-1234yf	122 35
Sniffer line adapter for system integration	525-005	Test leaks for refrigerants (10 - 14 g/a)	
Sniffer tips		R134a	122 40
ST 312, 120 mm, rigid	122 13	R600a	122 41
FT 312, 120 mm, flexible	122 14	R404a	122 42
ST 200, 200 mm, rigid	122 18	R502	122 43
FT 250, 250 mm, flexible	122 66	R744 (CO ₂)	122 75
ST 385, 385 mm, rigid	122 15		
FT 385, 385 mm, flexible	122 16		
FT 600, 600 mm, flexible	122 09		
ST 400, 400 mm, 45° angled	122 72		
Holder for sniffer line SL3000	525-006		
Cover for reference leak port	525-007		
Water protection tip for SL3000	122 46		

Multi-Gas Leak Detector Ecotec E3000A

The Ecotec E3000A multi-gas leak detector is the reliable and low-cost solution for testing cooling circuits in airplanes. Simpler and measurably faster than conventional leak-testing methods, the Ecotec E3000A does not require evacuation. It simply “sniffs” for refrigerant leaks while the system is in use, reducing downtime and waste.

It comes with a library of more than 100 detectable gases including all refrigerants and heat transfer fluids used in Airbus airplanes as well as many other commonly used gases.

The Ecotec E3000A is officially recommended for use in the A340 (for more information see AMM A340 chapter 25) and the next-generation A380 (AMM A380 chapter 21).



USER ADVANTAGES

- Improved system design compensates for poor sniffing operation reducing the potential for missed leaks
- Built-in, adjustable illumination helps operators precisely position the tip even in tight compartments where light is limited
- Simpler and measurably faster than conventional testing methods
- Does not require evacuation
- Less downtime for airplanes
- Fewer instances where food cannot be served because of refrigeration issues, resulting in better customer service
- Pinpoints the exact location of the leak
- Detected leak rate can be read from the probe display as numerical value
- Can detect up to four different gases at the same time
- Wheeled transportation case that holds all accessories to be easily hauled around the airplane
- Recommended in AMM A340, Chapter 25 and AMM A380, Chapter 21

TYPICAL APPLICATIONS

Leak testing of

- Galley systems
- Transfer lines
- Main chiller system
- Air conditioning system
- Fire extinguishing system

SPECIFICATIONS	ECOTEC E3000A
Minimum detectable leak rate	0.05 g/a (0.02 oz/yr)
Measuring scale	0.5 – 50 g/a (0.02 – 1.76 oz/yr)
Response time	< 1s
Leak rate units	g/a; oz/yr; lb/yr; mbar l/s; Pa m ³ /s
Start-up time	< 2 min
Max no. of gases detected simultaneously	4
Interfaces	RS232
Dimensions (diameter; height)	580 x 260 x 350 mm (22.8 x 12.2 x 13.8 in)
Weight	34 kg (75 lbs)
Gas flow	160 sccm
Ambient temperature range	10-45 °C (50-113 °F)
Software available in	English, German, Spanish, French, Italian, Portugese, Chinese, Japanese (Katakana)
Warranty	2 years
ORDERING INFORMATION	PART NUMBER
<p>Ecotec E3000A including:</p> <p>5 m sniffer line, power plug adapter for all major regions, 120 mm rigid sniffer tip, 385 mm flexible sniffer tip, built-in ECO-Check reference leak, transportation case</p> <p>230 V, 50 Hz 100/115 V, 50/60 Hz</p>	<p>530-101 530-102</p>

Refrigerant Sniffer Leak Detector HLD5000

The HLD5000 refrigerant leak detector uses an innovative technology to find leaks quickly and reliably with dramatically fewer false alarms.

With its IR sensor it is designed to only detect refrigerant leaks. It reliably suppresses any signals caused by other gases present in the atmosphere. Numerous other features enhance the units convenience, reliability and durability. A selection of probes for single gases as well as a universal probe for all halogen-based refrigerants is available.

The present HLD5000 is the best leak detector in its class.



USER ADVANTAGES

Highly reliable detection of leaks

- No false alarms due to background compensation by dual inlet technology
- No cross sensitivity to non-halogens (water, breath, etc)
- No undetected leaks due to undetected malfunctioning of the leak detector as functionality is constantly monitored
- Short response time for fast use

Universal base unit for high flexibility

- Universal base unit with different probes
- Selection of different probes for single refrigerants including non-halogens (CO₂, R600a/R290, R134a)
- Universal probe for all halogen-based refrigerants (R32, HFO-1234yf, etc.)
- Unit can be switched over by simply connecting a different sniffer line

Easy to operate

- ATM-like display
- Visual (probe and base unit) and acoustic alarm
- Integrated test leak for easy and traceable calibration at the line as well as regular verification of the calibration
- May be used in automated testing systems with digital processing of test data via RS232 interface

Low cost of operation

- Reliable operation of the unit and very low cost of operation
- Long sensor life, resistant to water intake

TYPICAL APPLICATIONS

- Air conditioning systems
- Automotive air conditioning units (R134a, HFO-1234yf)
- Heat pumps
- Compressors and tubing
- CO₂ components
- Components or systems filled with SF₆

SPECIFICATIONS		HLD5000
Detectable refrigerant	single gas probe universal Smart Probe	R134a; R744 (CO ₂), SF ₆ all halogen-based refrigerants
Minimum detectable leak rate	single gas probe universal Smart Probe	1 g/a (0.03 oz/yr) 0.5 g/a (0.014 oz/yr)
Measuring scale	single gas probe universal Smart Probe	0 - 100 g/a (3.57 oz/yr) 0 - 300 g/a (10.7 oz/yr)
Response time		< 1 s
Leak rate units		g/a; mbar l/s; oz/yr; lb/yr; Pa m ³ /s, ppm
Warm-up time		30 s
Dimensions (diameter; height)		260 mm (10.25 in.); 365 mm (14.4 in.)
Weight		4.5 kg (10 lbs)
Length of sniffer line		4.8 m (15.5 ft.)
Standard sniffer tip length		100 mm (3.9 in.)
Gas flow		320 sccm
Ambient temperature range		5 - 50°C (40 - 120°F)

ORDERING INFORMATION	PART NUMBER
HLD5000, includes complete sniffer probe (4.8 m / 15.5 ft) with standard sniffer tip (100 mm / 3.9 in.) and COOL-Check reference leak	
R134a ³	510-010
R744 (CO ₂)	510-015
Universal Smart probe ³	510-017
R600a/R290a	510-018
Additional sniffer probes sold separately	
R134a	511-030
R744 (CO ₂)	511-035
Universal Smart probe	511-037
R600a/R290a	511-038
Options, Accessories	
Sniffer tip, 100 mm (3.9 in.)	511-021
Sniffer tip, 400 mm (15 in.)	511-024
Sniffer tip, 400 mm (15 in.), prebent to half circle	511-022
Extension, 400 mm (15.7 in.) for sniffer tip	511-020
Extension, 500 mm (19.7 in.) for sniffer tip, 45° offset	511-029
Water protection tip	511-025
Extension for probe cable, 4.8m (15.5 ft)	511-040
Adapter for R744 (CO ₂) calibration ¹	511-042
Consumables	
Set of tip filter holders (20 pcs.)	511-027
Set of filter cartridges	511-018
Replacement COOL-Check reference leak ²	511-010
External calibrated test leaks for refrigerants: please refer to page 40	

¹ included in delivery of HLD5000 for CO₂ (510-015)

² limited shelf life, purchase only when needed

³ included COOL-Check reference leak

Hydrogen Leak Detector Sensistor ISH2000

The Sensistor ISH2000 Hydrogen Leak Detector is a robust instrument for professional leak detection. It is the best choice in environments where large leaks occur occasionally. The unique method involving the use of inexpensive forming gas (5 % hydrogen and 95 % nitrogen) as tracer gas combines unmatched measuring properties with user friendly technology, low costs and minimal service requirements. This makes Sensistor ISH2000 the best option for a wide range of production and maintenance applications, especially for finding leaks with leaking liquids such as water, fuel and oils. With its unique capability to handle high gas concentrations, the Sensistor ISH2000 is superior in precisely pinpointing leak location, irrespective of leak size.

Sensistor ISH2000 Hydrogen Leak Detector are available as desktop-, panel- and battery-operated versions. The desktop- and battery version is delivered with the P50 hand Probe.



Sensistor ISH2000 desktop unit with hand probe P50

USER ADVANTAGES

- High sensitivity combined with excellent performance in high concentrations
- Short recovery time reduces downtime when detecting gross leaks
- Ergonomic hand probe with built-in intelligence facilitates the operator's control of the instrument
- Easy sensor fitting makes it simple to replace the sensor in a matter of seconds
- Low maintenance – no moving parts
- Long autonomy – fast charging (for battery-powered model)
- Automatic and manual zero setting eliminates problems with high background levels of tracer gas. Simply push a button to eliminate background disturbance
- LED Leak/Tight indication in the hand probe provides the operator with fast information during the leak detection process
- Alternative alarms through different types of audio signals and/or visual indicators on the screen
- Highly selective hydrogen sensor
- Password protection on different levels
- Multi-point measurement with accumulation of the values makes it possible to add several leaks and compare with the total threshold value

TYPICAL APPLICATIONS

The combination of inexpensive tracer gas, flexible testing procedures and high reliability makes Sensistor ISH2000 the optimal solution for a variety of demanding applications – both in production, repair lines and maintenance.

- Industry
- Automotive
- Aerospace
- Packaging
- RAC
- Medical
- Process



Sensistor ISH2000C, portable, battery-operated unit for use in rough environments

SPECIFICATIONS**SENSISTOR ISH2000**

Minimum detectable leak rate Detection Mode with P50 standard probe Analysis Mode with P50 standard probe	1×10^{-7} mbar l/s or cc/s with 5 % H ₂ 0.5 ppm H ₂ ; 5×10^{-7} mbar l/s or cc/s with 5% H ₂
Start time	1 min
Calibration	external reference leak or calibration gas
Operating time (Sensistor ISH2000C)	> 9 h at 20°C (68°F)
Charging time (Sensistor ISH2000C)	< 7 h at 20°C (68°F)
Inputs / Outputs	25 pin, D-Sub with status signals 24 V DC / 0.5A 9 pin, D-Sub with RS232 probe connector (Sensistor ISH2000P)
Maintenance	maintenance-free
Power supply Sensistor ISH2000 Sensistor ISH2000P Sensistor ISH2000C	100 – 240 V AC, 50/60 Hz, 2 A 24 V DC, 3 A Internal, rechargeable battery ¹ (Li-Ion)
Dimensions (W x H x D) Sensistor ISH2000 Sensistor ISH2000P Sensistor ISH2000C	275 x 155 x 170 mm (11 x 6 x 7 in.) 275 x 140 x 75 mm (11 x 6 x 3 in.) 275 x 190 x 170 mm (11 x 7 x 7 in.)
Weight Sensistor ISH2000 Sensistor ISH2000P Sensistor ISH2000C	3.9 kg (8.6 lbs) excl. probe and probe cable 1.8 kg (4.0 lbs) 4.0 kg (8.8 lbs) excl. probe and probe cable
	¹ charged, using adapter supplied, 100-240 V, 50/60 Hz, 0.3 A

ORDERING INFORMATION

	PART NUMBER		PART NUMBER
Sensistor ISH2000, desktop unit Including hand probe P50	590-750	Counter flow probe AP57, provides a protective air curtain against a high background level of tracer gas	590-555
Sensistor ISH2000P, unit for panel mounting for full or semi-automatic leak detection	590-760	Tracer gas filler TGF10, for controlled filling and evacuation of tracer gas in the object	590-557
Sensistor ISH2000C, portable, battery-powered unit Including hand probe P50, battery charger and carrier bag with shoulder strap	590-770	Sensistor ILS500 F leak detection filler	590-596
Accessories:		Probe cables C21	
Hand Probe P50	590-780	3 m, 9.8 ft.	590-161
Hand Probe P50 Flex	590-790	6 m, 19.6 ft.	590-175
Robot Probe R50	590-920	9 m, 29.5 ft.	590-165
Sampling probe AP29ECO, for automatic leak testing		Insert sensor H65, replaces the standard hand probe in automated tests.	
3 cc/s sample flow	590-035	Requires a Combox	590-250
1 cc/s sample flow	590-036	Reference leaks ²	on request
Sniffer probe AP55, for fast manual leak location in hard-to-reach places	590-550	Combox for connecting AP29ECO, H65, AP55, AP57 to ISH2000	590-820

² please contact us for our range of matching reference leaks

Hydrogen Leak Detection System ILS500

The Sensistor ILS500 is a fully integrated leak testing system controlling tooling, tracer gas handling, test sequencing and leak testing — all behind an easy to use touch screen interface. The instrument is extremely compact but also detachable for optimal testing conditions, shorter cycle times and increased operator convenience according to the specific test situation.

Equipped with a wide range of accessories, the ILS500 meets all test requirements and offers a large variety of test possibilities. It is available in Standard, High Pressure, Combi Probe and Filler version.

The Filler version excludes the Hydrogen Detector and can be used in combination with other INFICON gas detectors.



USER ADVANTAGES

- Fully integrated leak testing system: includes gas handling, tooling control and leak detection
- Fast test procedure set up: guided installation on touch screen
- Reliable leak detection: highly selective and sensitive hydrogen sensor
- Fast sensor reaction, fast recovery: for fast testing and short cycle times
- Includes gross leak test prior to tracer gas test
- Available with dual probe funktion to enable manual leak locating after automatic chamber test
- Simple user interface: easy to learn and to operate
- Easy service and sensor change: for minimum down time
- Detachable components: for optimum performance and operator ergonomics
- Quick commissioning of test system with standard components
- Less operator dependence: full control over all test steps

TYPICAL APPLICATIONS

- Industry
- Automotive
- Aerospace
- Packaging
- RAC
- Medical
- Process

SPECIFICATIONS	SENSISTOR ILS500
Minimum detectable leak rate Detection mode with P50 standard probe Analysis mode with P50 standard probe	1x10 ⁻⁷ mbar l/s or cc/s with 5% H ₂ 0.5 ppm H ₂ ; 5x10 ⁻⁷ mbar l/s or cc/s with 5% H ₂
Start time	1 min
Calibration	external reference leak or calibration gas
Electrical supplies Mains voltage Current Power rating	single phase, 85-260 V(AC) / 47-63 Hz 1.0 A @ 100 V(AC) / 0.45 A @ 230 V(AC) 120 W max / 33 W typical average
Compressed air supplies Pressure Peak Consumption	0.35 – 0.7 MPa (50 – 100 psi) @ 0.6 MPa (87 psi): 240 l/min (508 SCFH)
Tracer gas supplies Recommended composition Pressure	5% H ₂ / 95% N ₂ 0.005 – 1.0 MPa (0.72 – 145 psi)
Evacuation Max vacuum Capacity	-85 kPa (-12.3 psi) 0.4 s/l to -50 kPa (-7.2 psi), 1.5 s/l to -80 kPa (-11.6 psi)
Filling capacity at 1 MPa supply	0.1 s/l to 0.1 MPa (14.5 psi), 0.5 s/l to 0.6 MPa (87 psi)
Tooling output valves Valve type	Normally closed, 3/2 valve Qn 160 std l/min., Cv 0.16 USGPM/psi
Gas and air connection:	Female ISO 3/8 in. (ISO to NPT 3/8 in., adapters included)
Temperature Humidity	10° - 40°C (50° - 100°F) 85% RH (non condensing)
Dimension (H x W x D)	295 mm x 275 mm x 330 mm (12 in. x 11 in. x 13 in.)
Weight	17.6 kg (38.8 lbs)
Communication Ports	Ethernet: RJ45; RS232: male, 9 pin, D-sub
Output Capacity	Max 0.5 A / output (max 2.5 A total), 24 VDC logic

ORDERING INFORMATION

PART NUMBER	PART NUMBER
Sensistor ILS500 versions, complete with hand probe PK50 and 3 m probe cable C21	No-Stop Maintenance Kit 590-680
Sensistor ILS500, 590-590	External Control Panel 590-650
Sensistor ILS500 HP (High Pressure) 590-592	External Control Panel with Emergency Stop 590-660
Sensistor ILS500 CP (Combi Probe) 590-593	Spare Parts:
Sensistor ILS500 CPHP 590-595	Sensor 590-292
Sensistor ILS500 F 590-596	Probe cables C21
Sensistor ILS500 FHP 590-598	3 m, 9.8 ft. 590-161
Accessories:	6 m, 19.6 ft. 590-175
Hand Probe PK50 590-930	9 m, 29.5 ft. 590-165
Hand Probe PK50 Flex 590-940	Insert sensor H65, replaces the standard hand probe in automated tests 590-250
Robot Probe R50 590-920	Reference leaks ¹ on request
Active Holder for hand probe 590-635	
Sampling probe AP29ECO, for automatic leak testing	
3 cc/s sample flow 590-035	
1 cc/s sample flow 590-036	

¹ please contact us for our range of matching reference leaks

Hydrogen Leak Detector Sensistor XRS9012

The Sensistor XRS9012 Hydrogen Leak Detector is a fast, reliable and robust instrument for utilities leak detection such as telecom cables and water pipes. The Sensistor XRS9012 offers a highly sensitive and flexible leak detection system in a heavy-duty, smart and ergonomically designed package. The unique method involving the use of inexpensive forming gas (5% hydrogen and 95% nitrogen) as tracer gas, combines unparalleled locating properties with user-friendly technology, low costs and minimal service requirements.

To be able to detect both minor and major leaks the Sensistor XRS9012 features a sensitivity adjuster to instantly adapt to any detection condition. The electronic sensor mounted in the probe tip responds instantaneously to the tracer gas. The sensor is also highly sensitive and selective to hydrogen gas. Additionally, the instrument has a very short recovery time to enable new measurements to be performed immediately.



USER ADVANTAGES

- Quick detection: High and adjustable sensitivity
- Reliable detection: Highly selective hydrogen sensor
- Ergonomic: Easy to carry and handle
- Easy to use: Just press ON. Automatic switch-off
- Quick charging in the car: 5 minutes for 20 minutes of operation
- Heavy-duty design: Waterproof aluminum casing (IP65)
- Minimal service requirements
- Wide range of accessories to adapt to various leak locating situations

TYPICAL APPLICATIONS

- Telephone cables – pressurized cables, buried or ducted
- All types of gas- and water pipelines
- Gas-filled power cables
- Gas stations
- Heating systems

SPECIFICATIONS**SENSISTOR XRS9012**

Sensitivity	0.7 ppm H ² in air
Response time	< 1 s
Warm-up time	< 6 s
Outputs	10-LED bar graph indicator, speakers, earphone, standard 3.5 mm (1/8") jack, > 8 ohms
Battery type	rechargeable lead batteries (gel electrolyte)
Battery capacity	13 hours at 20°C (68°F), 6 hours at -20°C (-4°F)
Maintenance	maintenance-free
Chargers	AC charger (100 - 240 V AC) car charger (9 - 15 V DC)
Casing	Aluminum
Protection	waterproof (IP65)
Dimensions in carrying case:	250 x 120 x 85 mm (9.85 x 4.75 x 3.35 in.) 260 x 220 x 95 mm (10.25 x 8.70 x 3.75 in.)
Weight in carrying case:	1.9 kg (4.2 lb) 2.5 kg (5.5 lbs)
Ambient temperature range	-20 - +50°C (-4 - +122°F)

ORDERING INFORMATION

	PART NUMBER		PART NUMBER
Sensistor XRS9012 Hydrogen Leak Detector, complete with nylon case, Probe H21, 3m (9.8 ft.) cable, mains input cable, waist belt, shoulder strap, earphones and cigarette lighter cable	590-012	Cable C21, 3 m (9.8 ft.) 6 m (19.6 ft.) 9 m (29.5 ft.)	590-161 590-175 590-165
Accessories:		Battery (order 3 pcs for complete change)	591-294
Hand probe H21	590-200	Charger	591-300
Hand probe extension P12	590-080	Charger adapter, 12 volt for charging in car	591-361
Surface probe 8612	590-040	Earphones	591-443
Wheel unit M12, accessory to 8612	590-070		
Ground probe 8212	590-020		
Duct probe 8712	590-051		

Ex certified Hydrogen Leak Detector EXTRIMA

The portable Extrima Ex certified Hydrogen Leak Detector is the ultimate explosion proof instrument for leak testing in the toughest of environments, including hazardous locations such as Zone 0 (corresponding to Division 1). It is certified for use in Zone 0, classification Ex ia, IIC T3 with ATEX, IECEx, NEPSI and CSA certificates.

Extrima is designed to withstand rough handling in the field and has a shoulder strap for easy carrying. The ergonomically designed hand probe with a built in leak/no leak LED indicator, together with the auto-range function and short recovery time, allows for fast homing in on suspected leak areas and exact leak pinpointing and quantification. The recommended tracer gas is a low cost standard forming gas (5% hydrogen and 95% nitrogen). It is non-flammable, non-corrosive, non-toxic and environmentally friendly.



USER ADVANTAGES

- Intrinsically safe: Ex ia, IIC T3
- Robust enclosure: for demanding field use
- Water proof: IP 67
- Battery operated: up to 12 hours autonomy
- Simple user interface: easy to learn and operate
- High sensitivity, fast recovery: for efficient operation
- Low and easy maintenance
- Sensor change in less than a minute
- Highly selective sensor
- Offers accessories for backtracing leaks in aircraft fuel systems

TYPICAL APPLICATIONS

- Process industry – e.g., pipe systems, valves and containers
- Aerospace – complete fuel systems, oxygen supply and fire extinguishing systems, both in production and maintenance
- Power production – hydrogen-cooled generators and fuel cells
- Offshore



EXTRIMA accessories:
Flex hand probe, injection pads, gas injection kit

SPECIFICATIONS	EXTRIMA
Ex classification	Ex ia IIC T3
Temperature	-20 to +50°C (-4 to +120°F)
Humidity	95% RH (non-condensing)
Chemical resistance	JET-fuel and most common petroleum products
IP-Class	IP67, 30 min@1m (IEC 60529)
Dimensions (HxWxD)	128 x 240 x 167 mm (5.03 x 9.44 x 6.57 in.)
Weight (hand probe excluded)	4.5 kg (10 lbs)
Application (mines and dust excluded)	Zones 0, 1 and 2 / Division 1 and 2 (hydrogen, JET-fuel, and other T1, T2 and T3 gases)
Sensitivity	
Analysis mode	0.5 PPM - 0.2% H ₂
Leak detection mode	1 x 10 ⁻⁷ cc/s (using 5 % H ₂ tracer gas)
Battery capacity	Up to 12 h (full charge)

ORDERING INFORMATION

	PART NUMBER		PART NUMBER
Extrima Ex certified Hydrogen leak detector, complete with detector, probe cable CX21 3 m (9.8 ft.). Hand probe with flexible neck PX57 Flex, shoulder strap, charger 100-240 V (AC), transport case, antistatic sensor caps, water protective tape	590-600	Injection pads (10 pack) Small, 60 mm (2.3 in.) Large, 150 mm (5.9 in.)	590-615 590-616
Accessories:		Injection fix kit	590-618
Hand probe (rigid neck) PX57	590-606	Injection panel	590-619
Flex hand probe (flexible neck) PX57	590-607	Complete gas injection kit	590-621
Probe cable CX21, 3 m (9.8 ft.)	590-260	Sensor	590-292
5 m (16.4 ft.)	590-265	Battery charger	591-656
Antistatic Sensor Caps (50-pack)	590-270	Reference leaks ¹	on request

¹ please contact us for our range of matching reference leaks

Calibrated Test Leaks for Sniffer Applications

The function of these leaks is based on a special quartz capillary which is customized to deliver a specific reduced flow from a test gas reservoir.

This type of calibrated test leaks is available in different leak rates and test gases (see ordering information).



USER ADVANTAGES

- Highly accurate and reliable due to the profile of the quartz capillary
- Metal-free capillary for low temperature dependance
- Inspection certificate (included) in accordance to DIN EN 10204:2004-3.1
- Determination of the nominal leak rate by comparison with a calibrated leak having a PTB certificate
- DKD certificate (optional) traceable to PTB

ORDERING INFORMATION

CALIBRATED LEAK	LEAK RATE RANGE	PART NUMBER
S-TL 4, with helium gas reservoir	10 ⁻⁴ mbar l/s	122 37
S-TL 5, with helium gas reservoir	10 ⁻⁵ mbar l/s	122 38
S-TL 6, with helium gas reservoir	10 ⁻⁶ mbar l/s	122 39
Calibrated sniffer test leaks for refrigerants		
2 - 5 g/a, 0.07 - 0.18 oz/y		
R134a		122 20
R600a		122 21
R404a		122 22
R502		122 23
R22		122 25
R152a		122 27
R407c		122 28
R410a		122 29
R401a		122 30
R290		122 31
R744 (CO ₂)		122 32
10% H ₂ / 90% H		122 33
R13B1 (Halon 1301)		122 34
HFO-1234yf		122 35
10 - 14 g/a, 0.36 - 0.5 oz/y		
R134a		122 40
R600a		122 41
R404a		122 42
R502		122 43
R744 (CO ₂)		122 75

Inquiry / Order form for Calibrated Leaks for System Applications

INFICON offers a wide variety of calibrated test leaks for almost every application demand.

To simplify the order process and to avoid unnecessary delays due to questions, please transmit the filled-in checklist to us. The feasibility will be checked according to your request.

CHECKLIST / ORDER FORM

for calibrated leaks for system applications

STEP 1

Please choose the **type** of the required test leak:

Calibrated leak with screw-in sleeve

Aluminum

Max. 40 bar / 580 psi

- Screw-in sleeve, 5 mm Ø Part.No. 143 00
- Screw-in sleeve, 6 mm Ø Part.No. 143 16

Calibrated leak with pin type casing

Max. 6 bar / 87 psi

- Pin-type casing and hose nozzle Part.No. 143 08
- Pin-type casing and VCO fitting Part.No. 143 04

Calibrated leak with cylindrical casing and VCO fitting

Max. 6 bar / 87 psi

- Cylindrical casing and VCO fitting Part.No. 143 12

STEP 2

Please state the pressure at the **low pressure side**:

- Low pressure side** Atmosphere
 Vacuum

Please state the required pressure at the **high pressure side**, the **pressure unit** and the **kind of pressure**:

- High pressure side** _____ bar
 psi

- Relative pressure **or**
- Absolute pressure (vacuum)

STEP 3

Please state the **gas type**:

_____ % Helium

_____ % Air

_____ % _____ (e.g. CO₂)

STEP 4

Please state the required **leak rate**:

_____ bar

(e.g. 3.4⁻⁵ or 0.0012) psi

Please state the **total leak rate** and **unit** for the above mentioned conditions.

INFICON will determine the equivalent for Helium.

Comments: _____

Please address this filled-in list to your local sales representative.

Thank you.



www.inficon.com reachus@inficon.com

Due to our continuing program of product improvements, specifications are subject to change without notice.

mila01e1-i (1302) ©2013 INFICON